



() Preliminary Specification

(V) Final Specification

Module	27.0" Color TFT-LCD
Model Name	M270QAN01.0

Customer	Date
_____	_____
Approved by	
_____	_____

Approved by	Date
<u>Howard Lee</u>	<u>May 7, 2015</u>
Prepared by	Date
<u>JiaHau Jean</u>	<u>May 7, 2015</u>

Note: This Specification is subject to change without notice.

AU Optronics corporation

Contents

1 Handling Precautions	4
2 General Description	5
2.1 Display Characteristics.....	5
2.2 Absolute Maximum Rating of Environment	6
2.3 Optical Characteristics	7
3 TFT-LCD Module	12
3.1 Block Diagram.....	12
3.2 Interface Connection.....	13
3.2.1 Connector Type.....	13
3.2.2 Connector Pin Assignment.....	13
3.3 Electrical Characteristics.....	16
3.3.1 Absolute Maximum Rating	16
3.3.2 Recommended Operating Condition.....	16
3.4 Signal Characteristics	17
3.4.1 LCD Pixel Format.....	17
3.4.2 eDP Data Format	18
3.4.3 Color versus Input Data	19
3.4.4 eDP Specification (Follow as VESA DisplayPort Standard Version 1.2)	20
3.4.5 Input Timing Specification	21
3.5 Power ON/OFF Sequence	22
4 Backlight Unit	23
4.1 Block Diagram.....	23
4.2 Interface Connection.....	24
4.2.1 Connector Type.....	24
4.3 Electrical Characteristics.....	26
4.3.1 Absolute Maximum Rating	27
4.3.2 Recommended Operating Condition.....	27
5 Reliability Test	29
6 Shipping Label	30
7 Mechanical Characteristics	31
8 Packing Specification	33
8.1 Packing Flow.....	33
8.2 Pallet and shipment information.....	34



Record of Revision

Version	Date	Page	Old description	New Description	Remark
0.1	2015/5/7	All	Specification release		

AUO Confidential For PROMATE Internal Use Only On 2016/11/03



1 Handling Precautions

- 1) Since front polarizer is easily damaged, pay attention not to scratch it.
- 2) Be sure to turn off power supply when inserting or disconnecting from input connector.
- 3) Wipe off water drop immediately. Long contact with water may cause discoloration or spots.
- 4) When the panel surface is soiled, wipe it with absorbent cotton or other soft cloth.
- 5) Since the panel is made of glass, it may break or crack if dropped or bumped on hard surface.
- 6) Since CMOS LSI is used in this module, take care of static electricity and insure human earth when handling.
- 7) Do not open or modify the Module Assembly.
- 8) Do not press the reflector sheet at the back of the module to any directions.
- 9) In case a TFT-LCD Module has to be put back into the packing container slot after once it was taken out from the container, do not press the center of the LED lightbar edge. Otherwise the TFT-LCD Module may be damaged.
- 10) Insert or pull out the interface connector, be sure not to rotate nor tilt it of the TFT-LCD Module.
- 11) Do not twist nor bend the TFT -LCD Module even momentary. It should be taken into consideration that no bending/twisting forces are applied to the TFT-LCD Module from outside. Otherwise the TFT-LCD Module may be damaged.
- 12) Please avoid touching COF position while you are doing mechanical design.
- 13) When storing modules as spares for a long time, the following precaution is necessary:
Store them in a dark place. Do not expose the module to sunlight or fluorescent light. Keep the temperature between 5 and 35 at normal humidity.

2 General Description

This specification applies to the 27.0 inch wide Color a-Si TFT-LCD Module M270QAN01.0. The display supports the UHD - 3840(H) x 2160(V) screen format and 1.07B colors (10bits RGB data input). The input interface is 8-lanes eDP and this module doesn't contain an driver board for backlight.

2.1 Display Characteristics

The following items are characteristics summary on the table under 25 condition:

ITEMS	Unit	SPECIFICATIONS
Screen Diagonal	[mm]	684 (26.93")
Active Area	[mm]	596.16 (H) x 335.34 (V)
Pixels H x V	-	3840x3(RGB) x 2160
Pixel Pitch	[um]	155.25 (per one triad) × 155.25
Pixel Arrangement	-	R.G.B. Vertical Stripe
Display Mode	-	Normally Black
White Luminance (Center)	[cd/m ²]	300 (Typ.)
Contrast Ratio	-	1000 (Typ.)
Response Time	[msec]	12 (Typ., Gray to Gray)
Power Consumption (LCD Module + Backligh unit)	[Watt]	Total = 44.6 (Typ.) LCD module : PDD (Typ.)=10.8 @ white pattern, 60Hz, 12 V Backlight unit : PBLU (Typ.) =33.8 @ Is=120mA
Weight	[Grams]	2820 (Typ.)
Outline Dimension	[mm]	613.6 (H) x 356.85 (V) × 14.5 (D) (Typ.)
Electrical Interface	-	8-lanes eDP , 10bits RGB data input
Support Color	-	1.07B colors
Surface Treatment	-	Anti-Glare, 3H
Temperature Range Operating Storage (Shipping)	[°C] [°C]	0 to +50 -20 to +60
RoHS Compliance	-	RoHS Compliance
TCO Compliance	-	TCO 6.0 Compliance

2.2 Absolute Maximum Rating of Environment

Permanent damage may occur if exceeding the following maximum rating.

Symbol	Description	Min.	Max.	Unit	Remark
TOP	Operating Temperature	0	+50	[°C]	Note 2-1
TGS	Glass surface temperature (operation)	0	+65	[°C]	Note 2-1 Function judged only
HOP	Operation Humidity	5	90	[%RH]	Note 2-1
TST	Storage Temperature	-20	+60	[°C]	
HST	Storage Humidity	5	90	[%RH]	

Note 2-1: Temperature and relative humidity range are shown as the below figure.

1. 90% RH Max (Ta 39)
2. Max wet-bulb temperature at 39 or less. (Ta 39)
3. No condensation

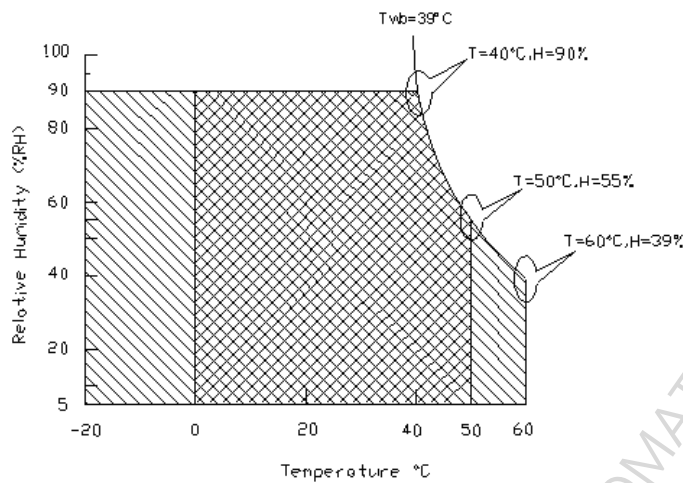

Operating Range



Storage Range

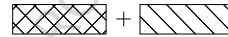

2.3 Optical Characteristics

The optical characteristics are measured on the following test condition.

Test Condition:

1. Equipment setup: Please refer to **Note 2-2**.
2. Panel Lighting time: 30 minutes
3. VDD=12.0V, Fv=60Hz, Is=120mA, Ta=25

Symbol	Description		Min.	Typ.	Max.	Unit	Remark
L _w	White Luminance (Center of screen)		240	300	-	[cd/m ²]	Note 2-2 By SR-3
L _{uni}	Luminance Uniformity (9 points)		75	80	-	[%]	Note 2-3 By SR-3
CR	Contrast Ratio (Center of screen)		600	1000	-	-	Note 2-4 By SR-3
θ _R	Horizontal Viewing Angle (CR=10)	Right	75	89	-	[degree]	Note 2-5 By SR-3
θ _L		Left	75	89	-		
Φ _H	Vertical Viewing Angle (CR=10)	Up	75	89	-		
Φ _L		Down	75	89	-		
T _{GTG}	Response Time	Gray to Gray	-	12	-	[msec]	Note 2-6 By TRD-100
R _x	Color Coordinates (CIE 1931) (TBD)	Red x	0.623	0.653	0.683	-	By SR-3
R _y		Red y	0.302	0.332	0.362		
G _x		Green x	0.262	0.292	0.322		
G _y		Green y	0.584	0.614	0.644		
B _x		Blue x	0.114	0.144	0.174		
B _y		Blue y	0.026	0.056	0.086		
W _x		White x	0.283	0.313	0.343		
W _y		White y	0.299	0.329	0.359		
sRGB coverage ratio			99	100		[%]	By SR-3
CT	Crosstalk		-	-	1.5	[%]	Note 2-7 By SR-3
F _{dB}	Flicker (Center of screen)		-	-	-20	[dB]	Note 2-8 By SR-3

Note 2-2: Equipment setup:

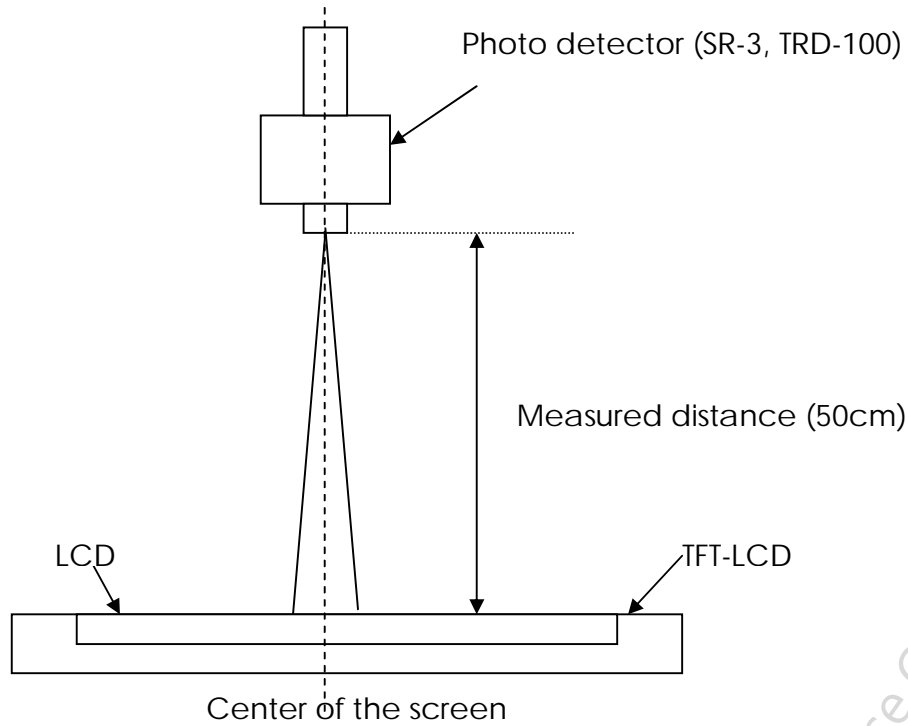

Note 2-3: Luminance Uniformity Measurement

Definition:

$$\text{Luminance Uniformity} = \frac{\text{Minimum Luminance of 9 Points (P1 ~ P9)}}{\text{Maximum Luminance of 9 Points (P1 ~ P9)}}$$

a. Test pattern: White Pattern

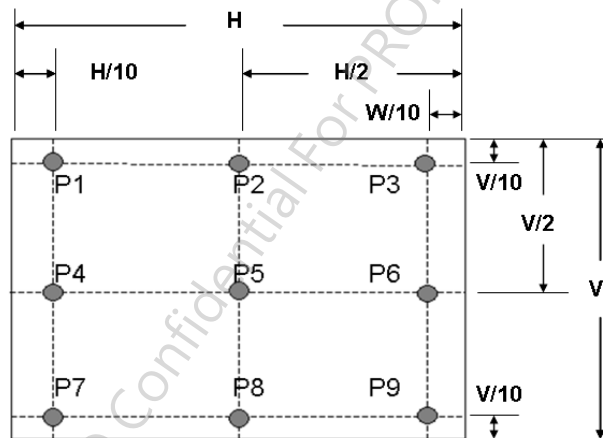

Note 2-4: Contrast Ratio Measurement

Definition:

$$\text{Contrast Ratio} = \frac{\text{Luminance of White pattern}}{\text{Luminance of Black pattern}}$$

- a. Measured position: Center of screen (P5) & perpendicular to the screen ($\theta = \Phi = 0^\circ$)

Note 2-5: Viewing angle measurement

Definition: The angle at which the contrast ratio is greater than 10 & 5 .

- a. Horizontal view angle: Divide to left & right (θ_L & θ_R)
Vertical view angle: Divide to up & down (Φ_H & Φ_L)

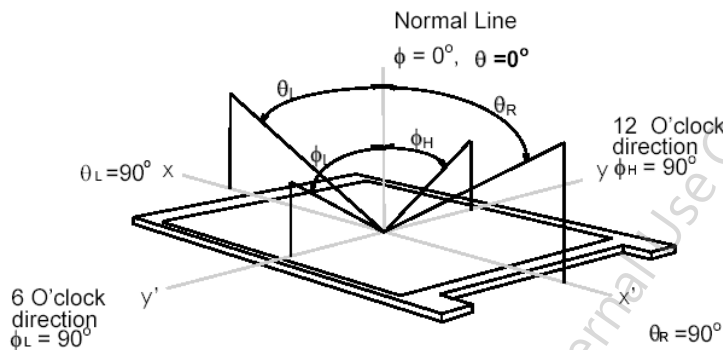

Note 2-6: Response measurement

The output signals of photo detector are measured when the input signals are changed from “Gray level A” to “Gray level B” (falling time, T_f), and from “Gray level B” to “Gray level A” (rising time, T_r), respectively. The response time is interval between the 10% and 90% of optical response.

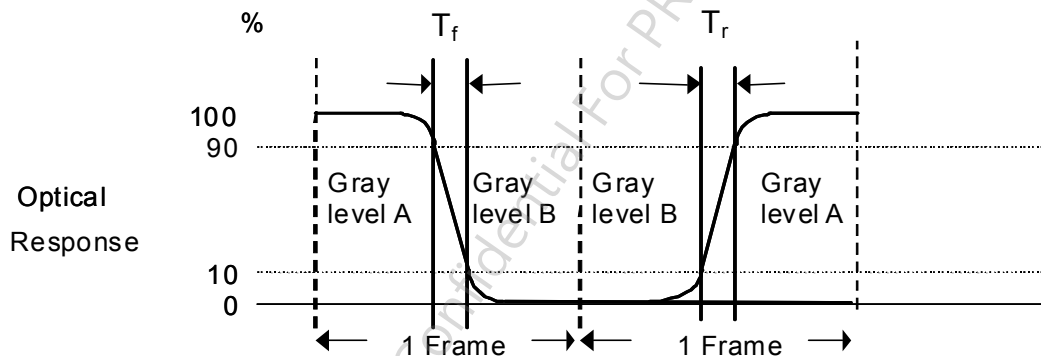

The gray to gray response time is defined as the following table.

Gray Level to Gray Level		Target gray level				
		L0	L255	L511	L767	L1023
Start gray level	L0					
	L255					
	L511					
	L767					
	L1023					

- T_{GTG_typ} is the total average time at rising time and falling time of gray to gray.

Note 2-7: Crosstalk measurement

Definition:

$$CT = \text{Max.} (CT_H, CT_V);$$

Where

- a. Maximum Horizontal Crosstalk:

$$CT_H = \text{Max.} (|Y_{BL} - Y_{AL}| / Y_{AL} \times 100 \%, |Y_{BR} - Y_{AR}| / Y_{AR} \times 100 \%);$$

Maximum Vertical Crosstalk:

$$CT_V = \text{Max.} (|Y_{BU} - Y_{AU}| / Y_{AU} \times 100 \%, |Y_{BD} - Y_{AD}| / Y_{AD} \times 100 \%);$$

- b. $Y_{AU}, Y_{AD}, Y_{AL}, Y_{AR}$ = Luminance of measured location without Black pattern

$Y_{BU}, Y_{BD}, Y_{BL}, Y_{BR}$ = Luminance of measured location with Black pattern

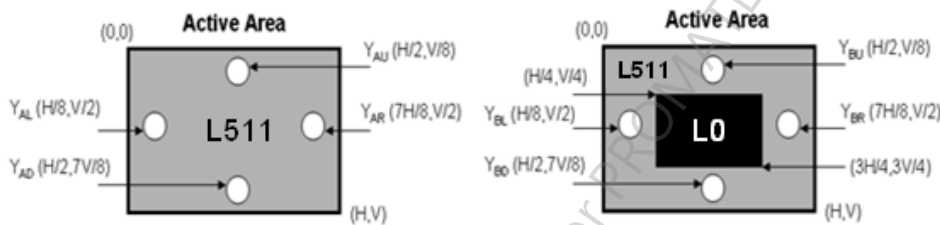

Note 2-8: Flicker measurement

a. Test pattern: It is listed as following.

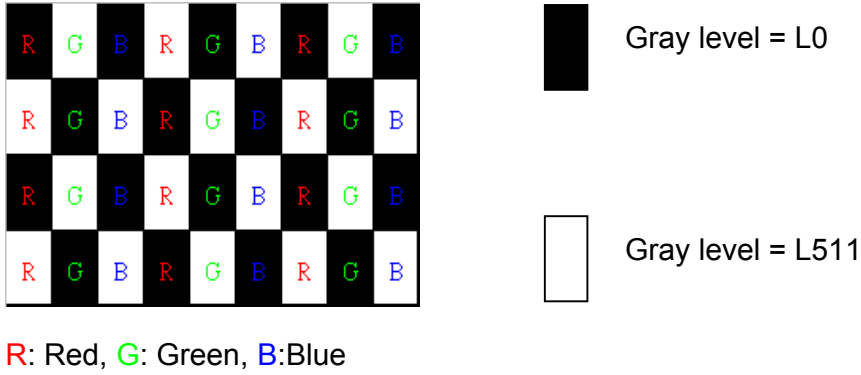

b. Measured position: Center of screen (P5) & perpendicular to the screen ($\theta=\Phi=0^\circ$)

AUO Confidential For PROMATE Internal Use Only On 2016/11/03

3 TFT-LCD Module

3.1 Block Diagram

The following shows the block diagram of the 27.0 inch Color TFT-LCD Module.

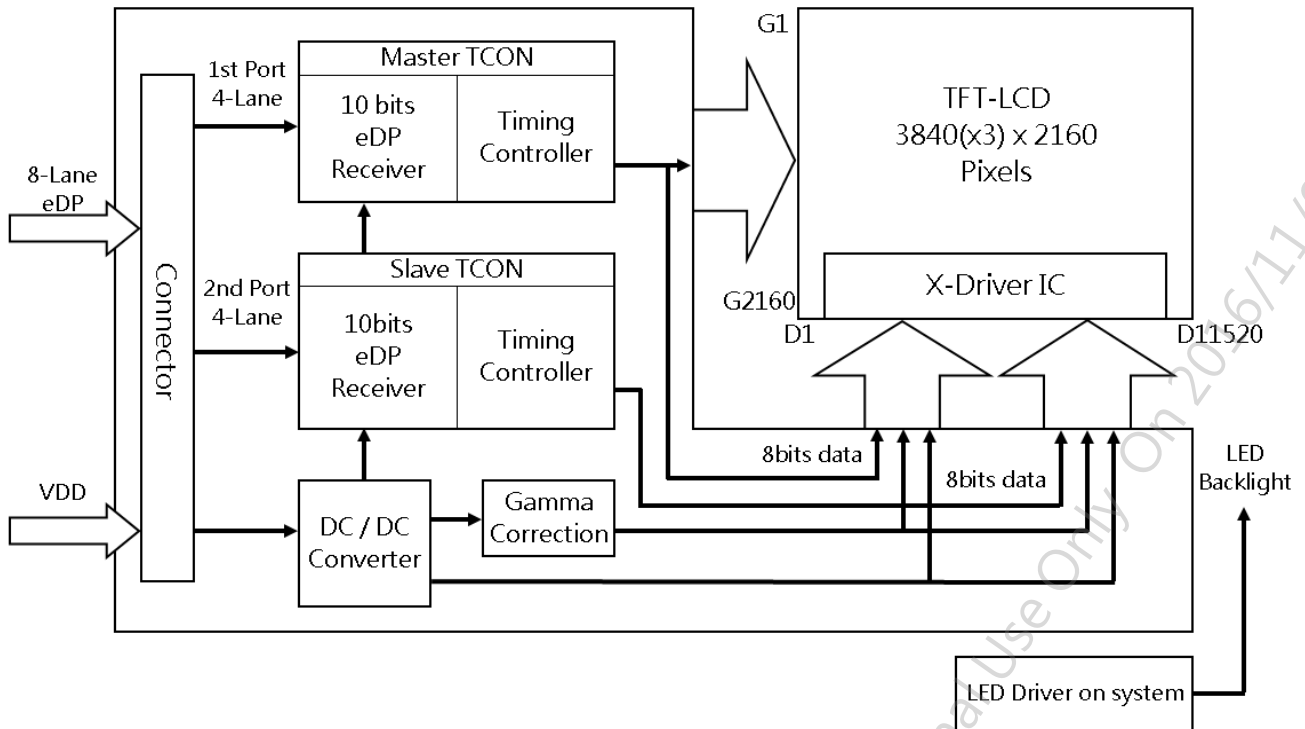



3.2 Interface Connection

3.2.1 Connector Type

TFT-LCD Connector	Manufacturer	P-TWO	JAE
	Part Number	187060-4122	FI-RE41S-HF
Mating Connector	Manufacturer	JAE or Compatible	
	Part Number	FI-RE41CL or Compatible	

3.2.2 Connector Pin Assignment

PIN #	Symbol	Description	Remark
1	1st Lane3_N	Negative eDP differential data input	
2	1st Lane3_P	Positive eDP differential data input	
3	GND	Ground	
4	1st Lane2_N	Negative eDP differential data input	
5	1st Lane2_P	Positive eDP differential data input	
6	GND	Ground	
7	1st Lane1_N	Negative eDP differential data input	
8	1st Lane1_P	Positive eDP differential data input	
9	GND	Ground	
10	1st Lane0_N	Negative eDP differential data input	
11	1st Lane0_P	Positive eDP differential data input	
12	GND	Ground	
13	1st AUX_CH_P	Positive AUX Channel differential data input	
14	1st AUX_CH_N	Negative AUX Channel differential data input	
15	1st HPD	Hot plug detection	
16	2nd Lane3_N	Negative eDP differential data input	
17	2nd Lane3_P	Positive eDP differential data input	
18	GND	Ground	
19	2nd Lane2_N	Negative eDP differential data input	
20	2nd Lane2_P	Positive eDP differential data input	



21	GND	Ground	
22	2nd Lane1_N	Negative eDP differential data input	
23	2nd Lane1_P	Positive eDP differential data input	
24	GND	Ground	
25	2nd Lane0_N	Negative eDP differential data input	
26	2nd Lane0_P	Positive eDP differential data input	
27	GND	Ground	
28	2nd AUX_CH_P	Positive AUX Channel differential data input	
29	2nd AUX_CH_N	Negative AUX Channel differential data input	
30	2nd HPD	Hot plug detection	
31	NC	No connection (for AUO test only. Do not connect)	
32	NC	No connection (for AUO test only. Do not connect)	
33	NC	No connection (for AUO test only. Do not connect)	
34	NC	No connection (for AUO test only. Do not connect)	
35	GND	Ground	
36	GND	Ground	
37	GND	Ground	
38	NC	No connection	
39	VDD	Power +12V	
40	VDD	Power +12V	
41	VDD	Power +12V	

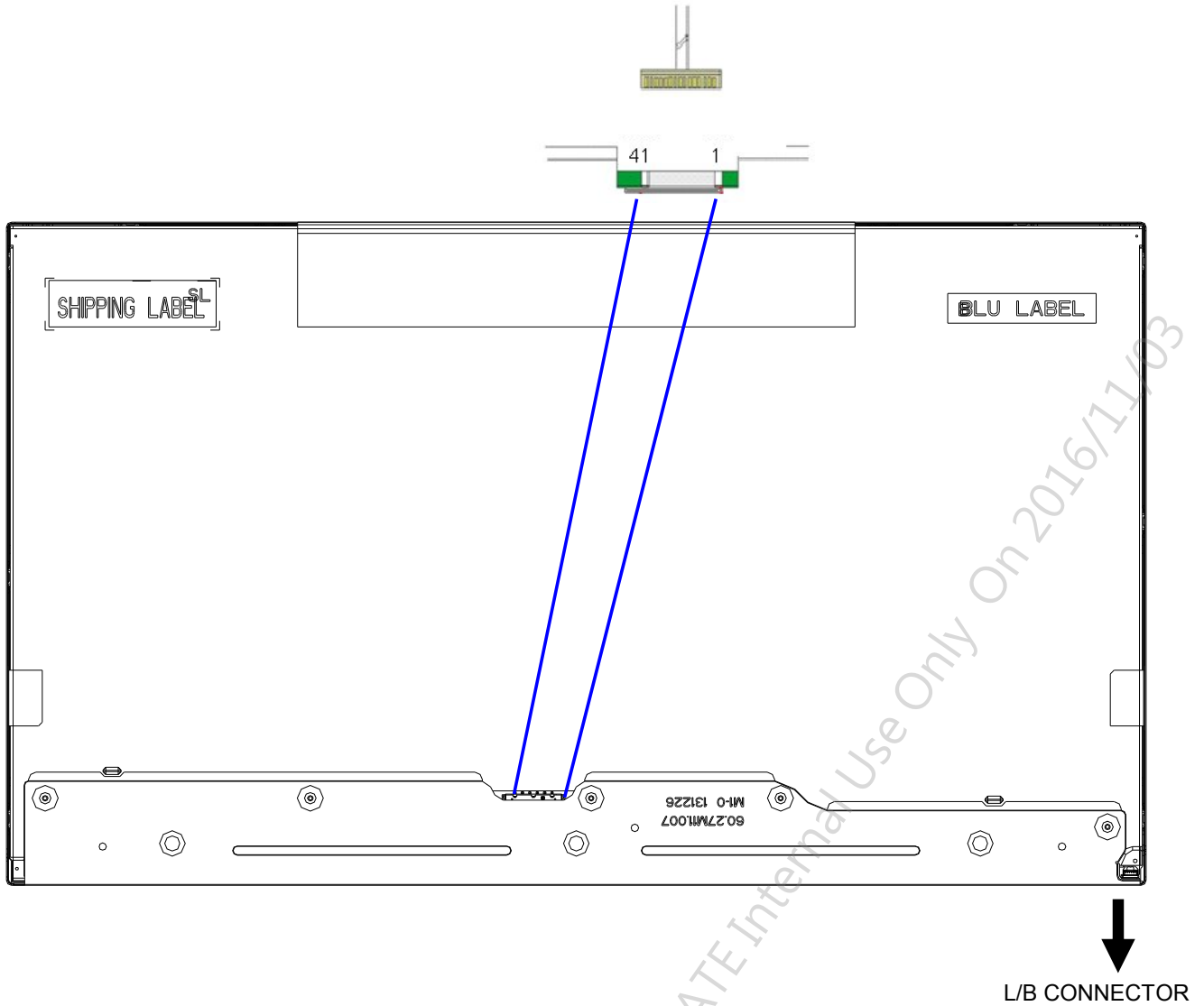

Note 3-1: Input signals of port 1 to port 4 clocks shall be the same timing.

3.3 Electrical Characteristics

3.3.1 Absolute Maximum Rating

Permanent damage may occur if exceeding the following maximum rating.

Symbol	Description	Min	Max	Unit	Remark
VDD	Power Supply Input Voltage	GND-0.3	14	[Volt]	Ta=25

3.3.2 Recommended Operating Condition

Symbol	Description	Min	Typ	Max	Unit	Remark
VDD	Power supply Input voltage	10.8	12.0	13.2	[Volt]	
IDD	Power supply Input Current (RMS)	-	0.9	1.1	[A]	VDD= 12.0V, White pattern, Fv=60Hz
PDD	VDD Power Consumption	-	10.8	13.2	[Watt]	VDD= 12.0V , White pattern, Fv=60Hz
IRush	Inrush Current	-	-	3	[A]	Note 3-2
VDDrp	Allowable VDD Ripple Voltage	-	-	VDD*5%	[mV]	VDD= 12.0V, White pattern, Fv=60Hz

Note 3-2: Inrush Current measurement:

Test circuit:

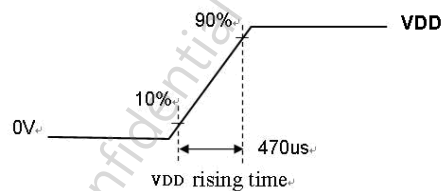
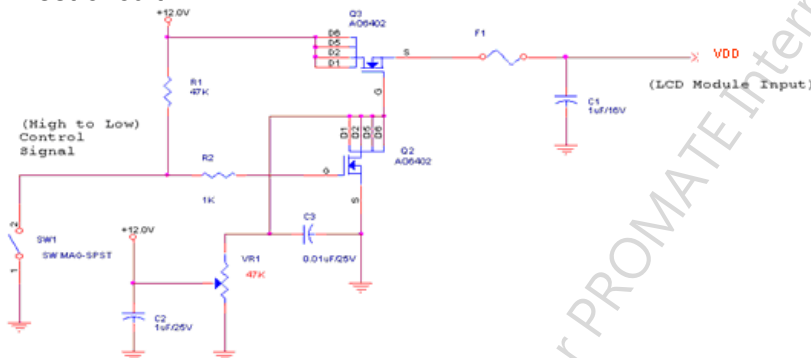

The duration of VDD rising time: 470us.

3.4 Signal Characteristics

3.4.1 LCD Pixel Format

Following figure shows the relationship between the input signals and LCD pixel format.

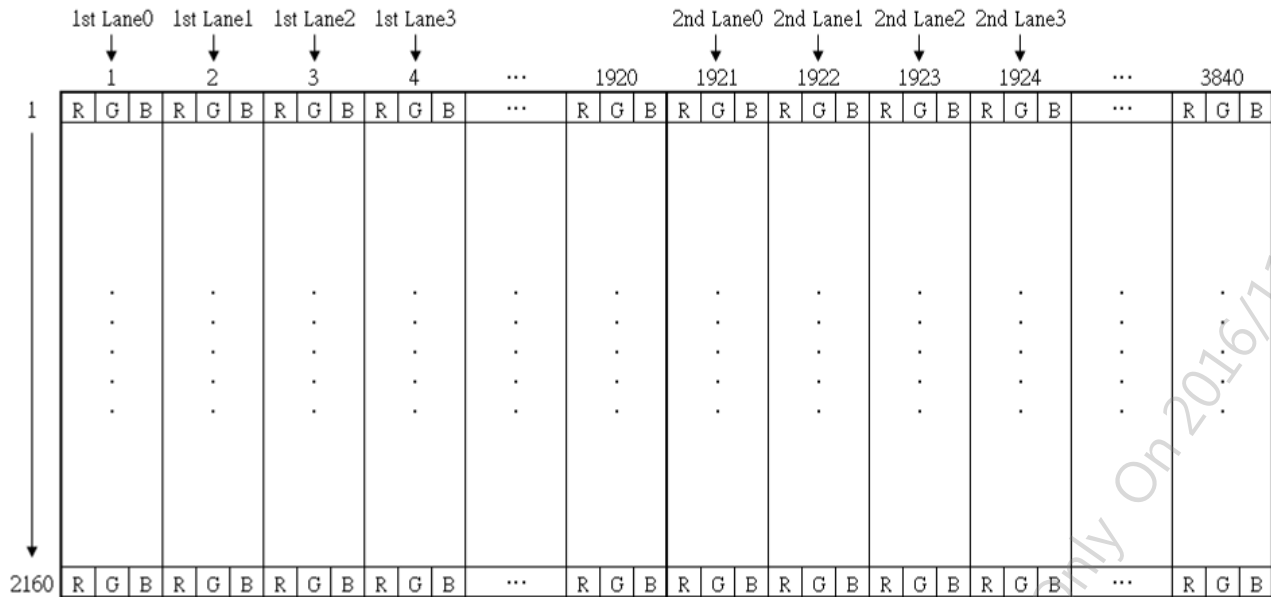

Note 3-3: The module use 8-Lanes eDP interface.

1st port:

1st Lane0 : $1+4n$ pixel

1st Lane1 : $2+4n$ pixel

1st Lane2 : $3+4n$ pixel

1st Lane3 : $4+4n$ pixel

2nd port:

2nd Lane0 : $1921+4n$ pixel

2nd Lane1 : $1922+4n$ pixel

2nd Lane2 : $1923+4n$ pixel

2nd Lane3 : $1924+4n$ pixel

$n=0\sim 479$



3.4.2 eDP Data Format

1st Lane0	1st Lane1	1st Lane2	1st Lane3
R1-9:2	R2-9:2	R3-9:2	R4-9:2
R1-1:0IG1-9:4	R2-1:0IG2-9:4	R3-1:0IG3-9:4	R4-1:0IG4-9:4
G1-3:0IB1-9:6	G2-3:0IB2-9:6	G3-3:0IB3-9:6	G4-3:0IB4-9:6
B1-5:0IR5-9:8	B2-5:0IR6-9:8	B3-5:0IR7-9:8	B4-5:0IR8-9:8
R5-7:0	R6-7:0	R7-7:0	R8-7:0
G5-9:2	G6-9:2	G7-9:2	G8-9:2
G5-1:0IB5-9:4	G6-1:0IB6-9:4	G7-1:0IB7-9:4	G8-1:0IB8-9:4
B5-3:0IR9-9:6	B6-3:0IR10-9:6	B7-3:0IR11-9:6	B8-3:0IR12-9:6
R9-5:0IG9-9:8	R10-5:0IG10-9:8	R11-5:0IG11-9:8	R12-5:0IG12-9:8
G9-7:0	G10-7:0	G11-7:0	G12-7:0
B9-9:2	B10-9:2	B11-9:2	B12-9:2
B9-1:0IR13-9:4	B10-1:0IR14-9:4	B11-1:0IR15-9:4	B12-1:0IR16-9:4
R13-3:0IG13-9:6	R14-3:0IG14-9:6	R15-3:0IG15-9:6	R16-3:0IG16-9:6
G13-5:0IB13-9:8	G14-5:0IB14-9:8	G15-5:0IB15-9:8	G16-5:0IB16-9:8
B13-7:0	B14-7:0	B15-7:0	B16-7:0
.	.	.	.
.	.	.	.
.	.	.	.
.	.	.	.
.	.	.	.

2nd Lane0	2nd Lane1	2nd Lane2	2nd Lane3
R1921-9:2	R1922-9:2	R1923-9:2	R1924-9:2
R1921-1:0IG1921-9:4	R1922-1:0IG1922-9:4	R1923-1:0IG1923-9:4	R1924-1:0IG1924-9:4
G1921-3:0IB1921-9:6	G1922-3:0IB1922-9:6	G1923-3:0IB1923-9:6	G1924-3:0IB1924-9:6
B1921-5:0IR1925-9:8	B1922-5:0IR1926-9:8	B1923-5:0IR1927-9:8	B1924-5:0IR1928-9:8
R1925-7:0	R1926-7:0	R1927-7:0	R1928-7:0
G1925-9:2	G1926-9:2	G1927-9:2	G1928-9:2
G1925-1:0IB1925-9:4	G1926-1:0IB1926-9:4	G1927-1:0IB1927-9:4	G1928-1:0IB1928-9:4
B1925-3:0IR1929-9:6	B1926-3:0IR1930-9:6	B1927-3:0IR1931-9:6	B1928-3:0IR1932-9:6
R1929-5:0IG1929-9:8	R1930-5:0IG1930-9:8	R1931-5:0IG1931-9:8	R1932-5:0IG1932-9:8
G1929-7:0	G1930-7:0	G1931-7:0	G1932-7:0
B1929-9:2	B1930-9:2	B1931-9:2	B1932-9:2
B1929-1:0IR1933-9:4	B1930-1:0IR1934-9:4	B1931-1:0IR1935-9:4	B1932-1:0IR1936-9:4
R1933-3:0IG1933-9:6	R1934-3:0IG1934-9:6	R1935-3:0IG1935-9:6	R1936-3:0IG1936-9:6
G1933-5:0IB1933-9:8	G1934-5:0IB1934-9:8	G1935-5:0IB1935-9:8	G1936-5:0IB1936-9:8
B1933-7:0	B1934-7:0	B1935-7:0	B1936-7:0
.	.	.	.
.	.	.	.
.	.	.	.
.	.	.	.
.	.	.	.

AUO Confidential For PROMATE Internal Use Only On 2016/11/03

3.4.3 Color versus Input Data

The following table is for color versus input data (10bit). The higher the gray level, the brighter the color.

Color	Gray Level	Color Input Data																												Remark		
		RED data (MSB:R9,LSB:R0)										GREEN data (MSB:G9,LSB:G0)										BLUE data (MSB:B9,LSB:B0)										
		R9	R8	R7	R6	R5	R4	R3	R2	R1	R0	G9	G8	G7	G6	G5	G4	G3	G2	G1	G0	B9	B8	B7	B6	B5	B4	B3	B2		B1	B0
Black	-	0	0	0	0	0	0	0	0	0	0	0	0	0	0	0	0	0	0	0	0	0	0	0	0	0	0	0	0	0	0	
White	-	1	1	1	1	1	1	1	1	1	1	1	1	1	1	1	1	1	1	1	1	1	1	1	1	1	1	1	1	1	1	
L511	-	0	1	1	1	1	1	1	1	1	1	0	1	1	1	1	1	1	1	1	1	0	1	1	1	1	1	1	1	1		
Red	L0	0	0	0	0	0	0	0	0	0	0	0	0	0	0	0	0	0	0	0	0	0	0	0	0	0	0	0	0	0	Black	
	:	:	:	:	:	:	:	:	:	:	:	:	:	:	:	:	:	:	:	:	:	:	:	:	:	:	:	:	:	:	:	
	L1023	1	1	1	1	1	1	1	1	1	1	0	1	1	1	1	1	1	1	1	1	0	1	1	1	1	1	1	1	1		
Green	L0	0	0	0	0	0	0	0	0	0	0	0	0	0	0	0	0	0	0	0	0	0	0	0	0	0	0	0	0	0	Black	
	:	:	:	:	:	:	:	:	:	:	:	:	:	:	:	:	:	:	:	:	:	:	:	:	:	:	:	:	:	:	:	
	L1023	0	0	0	0	0	0	0	0	0	0	1	1	1	1	1	1	1	1	1	1	0	0	0	0	0	0	0	0	0		
Blue	L0	0	0	0	0	0	0	0	0	0	0	0	0	0	0	0	0	0	0	0	0	0	0	0	0	0	0	0	0	Black		
	:	:	:	:	:	:	:	:	:	:	:	:	:	:	:	:	:	:	:	:	:	:	:	:	:	:	:	:	:	:	:	
	L1023	0	0	0	0	0	0	0	0	0	0	0	0	0	0	0	0	0	0	0	0	1	1	1	1	1	1	1	1	1		

3.4.4 eDP Specification (Follow as VESA DisplayPort Standard Version 1.2)

a. DisplayPort main link signal:

DisplayPort main link					
		Min	Typ	Max	unit
VCM	RX input DC Common Mode Voltage	0	-	2.0	V
VDiff _{P-P}	Peak-to-peak Voltage at a receiving Device	120	-	-	mV

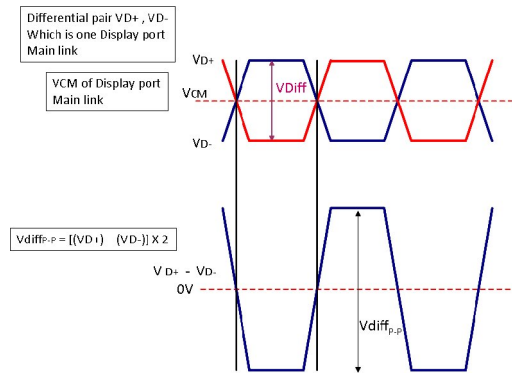

b. DisplayPort AUX_CH signal:

DisplayPort AUX_CH					
		Min	Typ	Max	unit
VCM	AUX DC Common Mode Voltage	0	0.5	2.0	V
VDiff _{P-P}	AUX Peak-to-peak voltage at a receiving device	0.32	0.6	1.32	V

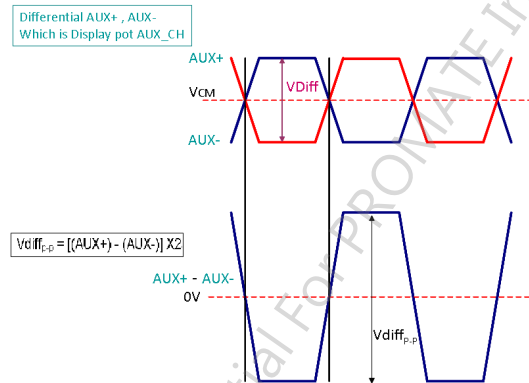

c. DisplayPort VHPD signal:

DisplayPort VHPD					
		Min	Typ	Max	unit
VHPD	HPD Voltage	2.25	-	3.6	V

3.4.5 Input Timing Specification

The input timing is shown as the following table.

Symbol	Description		Min.	Typ.	Max.	Unit	Remark
Tv	Vertical Section	Period	2180	2200	5260	Th	
Tdisp (v)		Active	2160	2160	2160	Th	
Tblk (v)		Blanking	20	40	3100	Th	
Fv		Frequency	29	60	65	Hz	Note 3-6 Note 3-7
Th	Horizontal Section	Period	2026	2100	2300	Tclk	
Tdisp (h)		Active	1920	1920	1920	Tclk	
Tblk (h)		Blanking	106	180	380	Tclk	
Fh		Frequency	109	132.00	142.20	kHz	Note 3-4
Tclk	Pixel Clock	Period	4.53	3.61	3.47	ns	1/Fclk
Fclk		Frequency	220.83	277.20	288.00	MHz	Note 3-5
Link Rate per Lane			2.7			Gbps	

Note 3-4: The equation is listed as following. Please don't exceed the above recommended value.

$$Fh \text{ (Min.)} = Fclk \text{ (Min.)} / Th \text{ (Min.)}$$

$$Fh \text{ (Typ.)} = Fclk \text{ (Typ.)} / Th \text{ (Typ.)}$$

$$Fh \text{ (Max.)} = Fclk \text{ (Max.)} / Th \text{ (Min.)}$$

Note 3-5: The equation is listed as following. Please don't exceed the above recommended value.

1st Lane N & 2nd Lane N skew < 200ns

$$Fclk \text{ (Typ.)} = Fv \text{ (Typ.)} \times Th \text{ (Typ.)} \times Tv \text{ (Typ.)}$$

$$Fclk \text{ (Min.)} = Fv \times Th \times Tv \quad Fclk \text{ (Max.)}$$

Note 3-6: The equation is listed as following. Please don't exceed the above recommended value.

$$Fv = Fclk \text{ (Typ.)} / (Tv \times Th)$$

Note 3-7: The optimal Vertical Frequency is 50~65 Hz for best picture quality.

3.5 Power ON/OFF Sequence

VDD power, eDP signal and backlight on/off sequence are as following. eDP signals from any system shall be Hi-Z state when VDD is off.

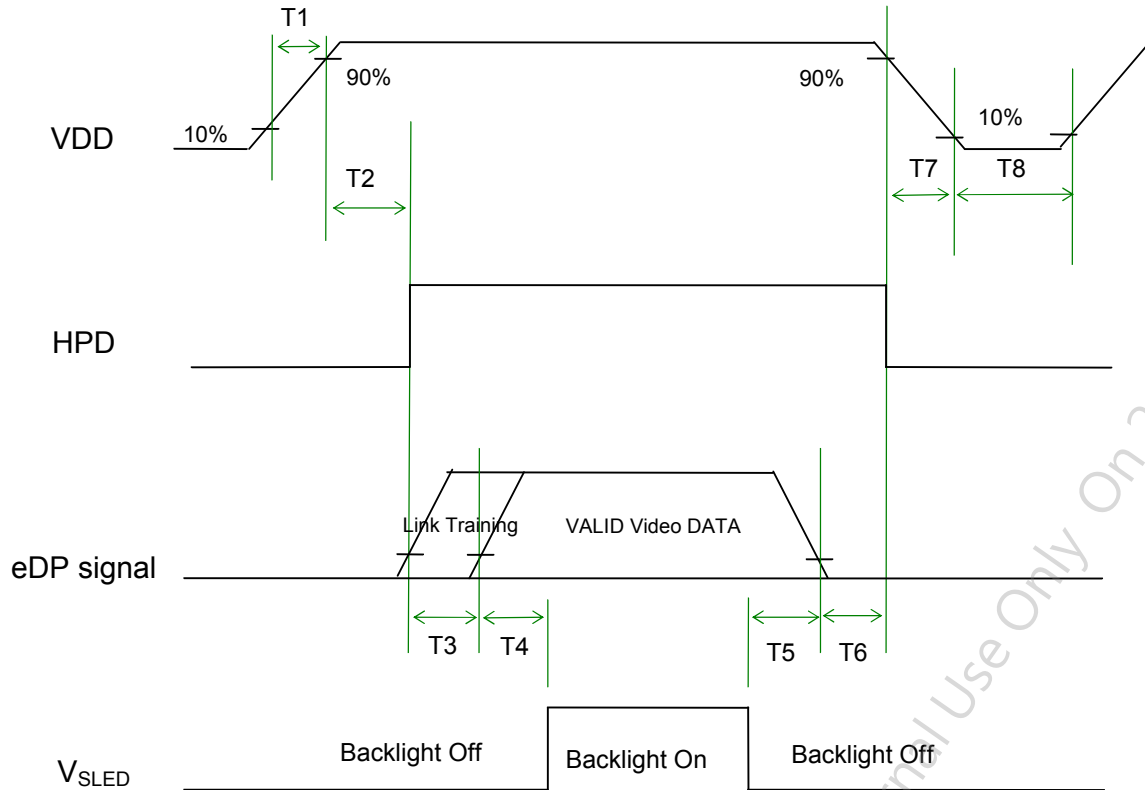

Power Sequence Timing

Symbol	Value			Unit	Remark
	Min.	Typ.	Max.		
T1	0.5	-	10	[ms]	
T2	0	-	200	[ms]	
T3	0	-	-	[ms]	Note 3-8
T4	500	-	-	[ms]	
T5	100	-	-	[ms]	
T6	0	-	50	[ms]	Note 3-9 Note 3-10
T7	0	-	200	[ms]	Note 3-10 Note 3-11
T8	1000	-	-	[ms]	

Note 3-8: During T3 period, eDP link training time by customer's system.

Note 3-9: Recommend setting T6 = 0ms to avoid electronic noise when VDD is off.

Note 3-10: During T6 and T7 period, please keep the level of input eDP signals with Hi-Z state.

Note 3-11: Voltage of VDD must decay smoothly after power-off. (customer system decide this value)

4 Backlight Unit

4.1 Block Diagram

The following shows the block diagram of the 27.0 inch Backlight Unit. Each LED light bar includes 88 pcs LED package. (4 strings and 22 pcs LED of one string).

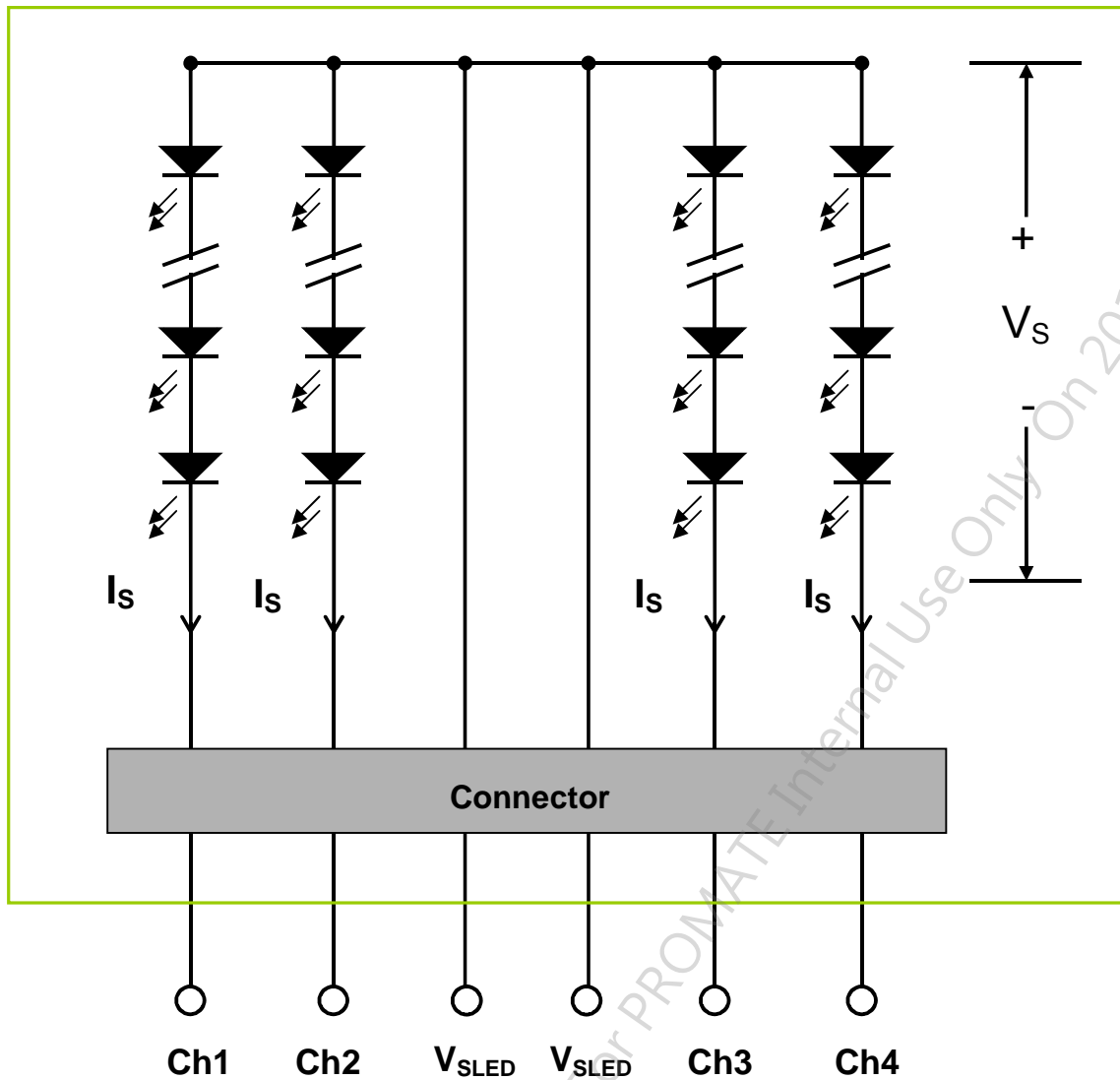

4.2 Interface Connection

4.2.1 Connector Type

Backlight Connector	Manufacturer	ENTERY
	Part Number	3707K-S06N-07R
Mating Connector	Manufacturer	ENTERY
	Part Number	H112K-P06N-13B (Locked type)

Backlight Connector dimension:

$H \times V \times D = 7.9 \times 5.05 \times 4.25$, Pitch = 1.0 (unit = mm)

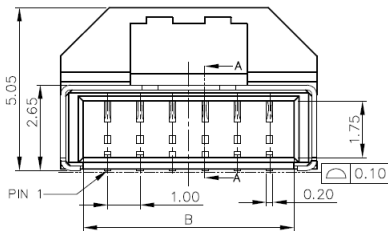
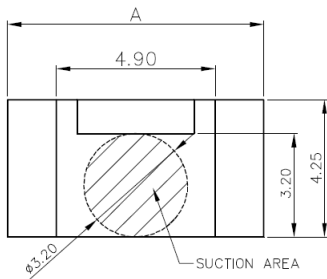

AUO Confidential For PROMATE Internal Use Only On 2016/11/03

Mating Connector dimension:

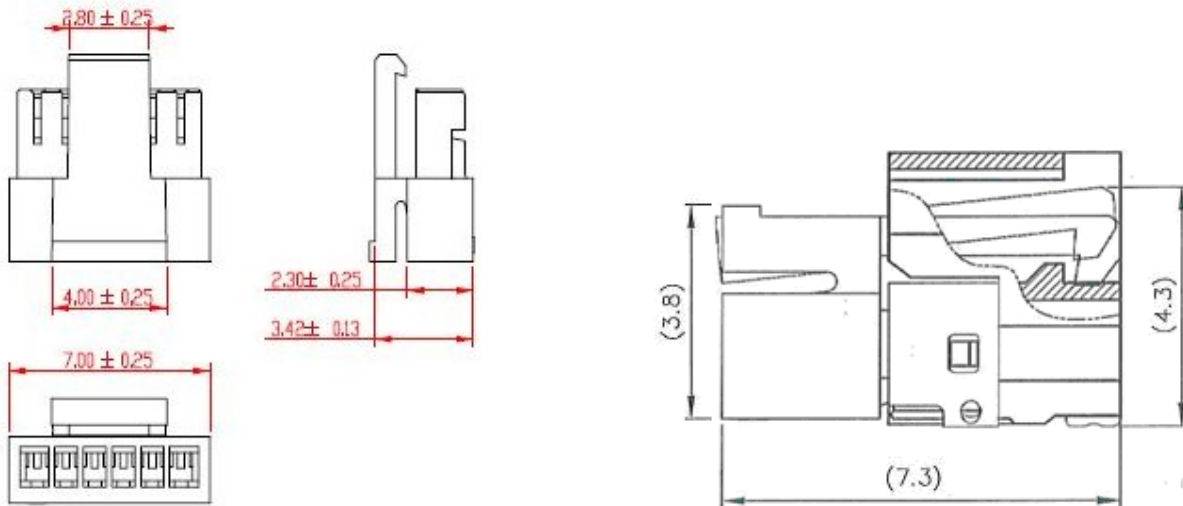

AUO Confidential For PROMATE Internal Use Only On 2016/11/03

4.2.2 Connector Pin Assignment

Pin#	Symbol	Description	Remark
1	Ch1	LED Current Feedback Terminal (Channel 1)	
2	Ch2	LED Current Feedback Terminal (Channel 2)	
3	V _{SLED}	LED Power Supply Voltage Input Terminal	
4	V _{SLED}	LED Power Supply Voltage Input Terminal	
5	Ch3	LED Current Feedback Terminal (Channel 3)	
6	Ch4	LED Current Feedback Terminal (Channel 4)	

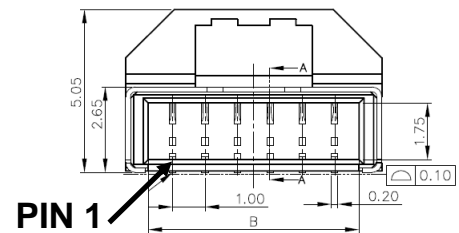
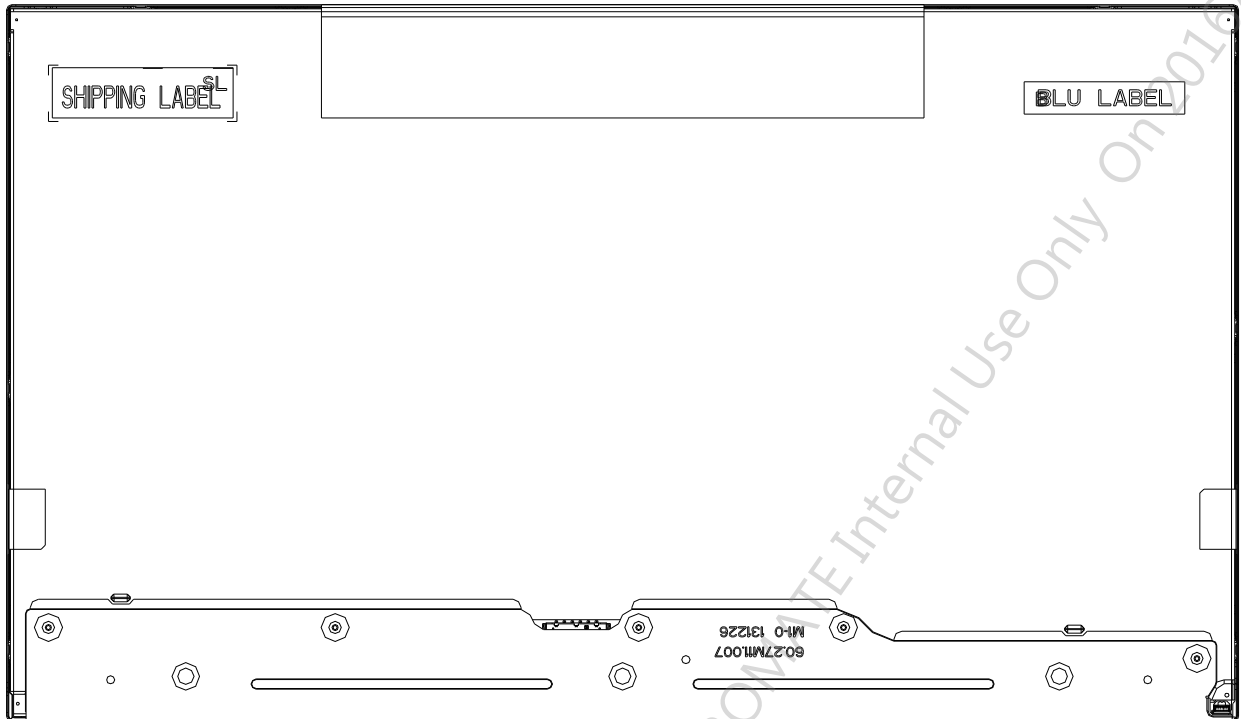

4.3 Electrical Characteristics

4.3.1 Absolute Maximum Rating

Permanent damage may occur if exceeding the following maximum rating.

(Ta=25)

Symbol	Description	Min	Max	Unit	Remark
Is	LED String Current	0	150	[mA]	100% duty ratio
			300	[mA]	Duty ratio 10% Pulse time=10 ms

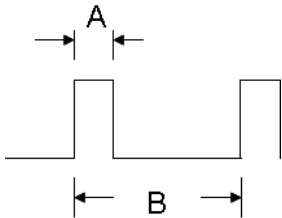

Duty ratio= (A / B) X 100% ; (A: Pulse time, B: Period)

4.3.2 Recommended Operating Condition

(Ta=25)

Symbol	Description	Min.	Typ.	Max.	Unit	Remark
Is	LED String Current		120	130	[mA]	100% duty ratio of LED chip
Vs	LED String Voltage	61.6	70.4	79.2	[Volt]	Is=120mA @ 100% duty ratio; Note 4-1&Note 4-5
ΔVs	Maximum Vs Voltage Deviation of light bar			4.4	[Volt]	Is=120mA @ 100% duty ratio; Note 4-2
P _{BLU}	LED Light Bar Power Consumption		33.8	38	[Watt]	Note 4-3
LT _{LED}	LED Life Time	30000			[Hour]	Note 4-4
OVP	Over Voltage Protection in system board	110% Vs(Max.)			[Volt]	Note 4-5

Note 4-1: V_s (Typ.) = V_F (Typ.) X LED No. (one string);

a. V_F : LED chip forward voltage, V_F (Min.)=2.8V, V_F (Typ.)=3.2V, V_F (Max.)=3.6V

b. The same equation to calculate V_s (Min.) & V_s (Max.) for respective V_F (Min.) & V_F (Max.);

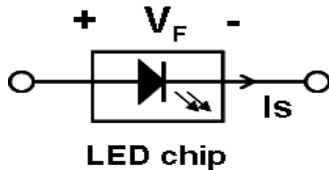

Note 4-2: ΔV_s (Max.) = ΔV_F X LED No. (one string);

a. ΔV_F : LED chip forward voltage deviation (0.2V , each Bin of LED V_F)

Note 4-3: P_{BLU} (Typ.) = V_s (Typ.) X I_s (Typ.) X 4 (4 is total String No. of BLU)

P_{BLU} (Max.) = V_s (Max.) X I_s (Typ.) X 4

Note 4-4: Definition of life time:

a. Brightness of LED becomes to 50% of its original value

b. Test condition: I_s = 120mA and 25 (Room Temperature)

Note 4-5: Recommendation for LED driver power design:

Due to there are electrical property deviation in LED & monitor set system component after long time operation. AUO strongly recommend the design value of LED driver board OVP (over voltage protection) should be 10% higher than max. value of LED string voltage (V_s) at least.

Note 4-6: AUO strongly recommend “Analog Dimming” method for backlight brightness control for Wavy Noise Free. Otherwise, recommend that Dimming Control Signal (PWM Signal) should be synchronized with Frame Frequency



5 Reliability Test

AUO reliability test items are listed as following table. (Bare Panel only)

Items	Condition	Remark
Temperature Humidity Bias (THB)	Ta= 50 , 80%RH, 300hours	
High Temperature Operation (HTO)	Ta= 50 , 50%RH, 300hours	
Low Temperature Operation (LTO)	Ta= 0 , 300hours	
High Temperature Storage (HTS)	Ta= 60 , 300hours	
Low Temperature Storage (LTS)	Ta= -20 , 300hours	
Vibration Test (Non-operation)	Acceleration: 1.5 Grms Wave: Random Frequency: 10 - 200 Hz Sweep: 30 Minutes each Axis (X, Y, Z)	
Shock Test (Non-operation)	Acceleration: 50 G Wave: Half-sine Active Time: 20 ms Direction: ±X, ±Y, ±Z (one time for each Axis)	
Thermal Shock Test (TST)	-20 /30min, 60 /30min, 100 cycles	Note 5-1
On/Off Test	On/10sec, Off/10sec, 30,000 cycles	
ESD (Electro Static Discharge)	Contact Discharge: ± 15KV, 150pF(330Ω) 1sec, 8 points, 25 times/ point.	Note 5-2
	Air Discharge: ± 15KV, 150pF(330Ω) 1sec 8 points, 25 times/ point.	
Altitude Test	Operation:18,000 ft Non-Operation:40,000 ft	

Note 5-1: a. A cycle of rapid temperature change consists of varying the temperature from -20 to 60 , and back again. Power is not applied during the test.

b. After finish temperature cycling, the unit is placed in normal room ambient for at least 4 hours before power on.

Note 5-2: EN61000-4-2, ESD class B: Certain performance degradation allowed

- No data lost
- Self-recoverable
- No hardware failures.

6 Shipping Label

The label is on the panel as shown below:

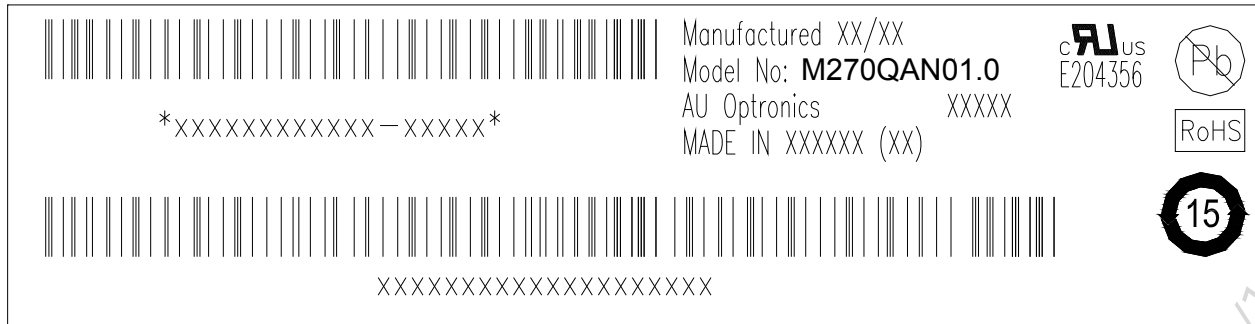

Note 6-1: For Pb Free products, AUO will add  for identification.

Note 6-2: For RoHS compatible products, AUO will add  for identification.

Note 6-3: For China RoHS compatible products, AUO will add  for identification.

Note 6-4: The Green Mark will be presented only when the green documents have been ready by AUO Internal Green Team.

AUO Confidential For PROMATE Internal Use Only On 2016/11/03

7 Mechanical Characteristics

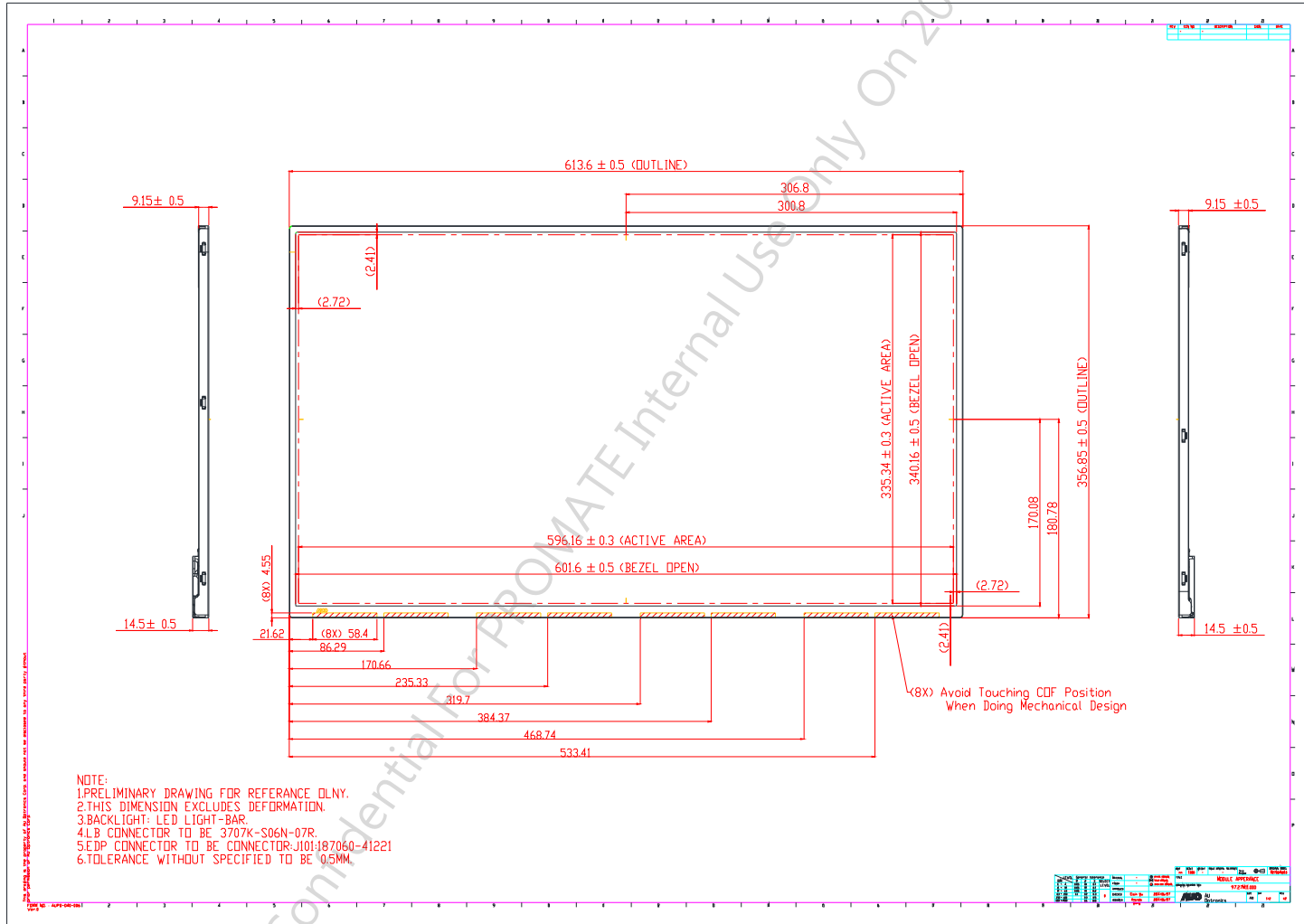

Ver 0.1

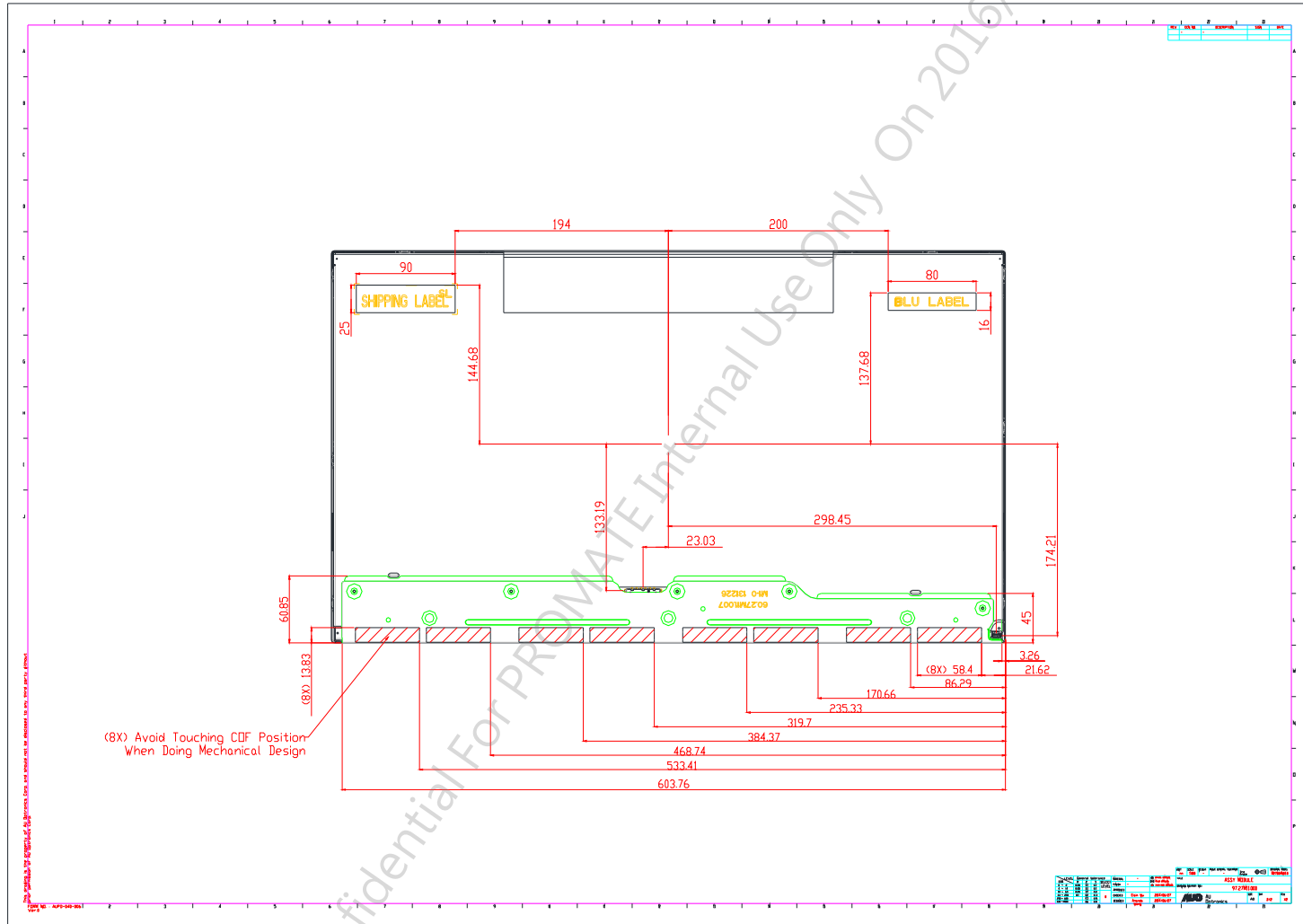

Ver 0.1

8 Packing Specification

8.1 Packing Flow

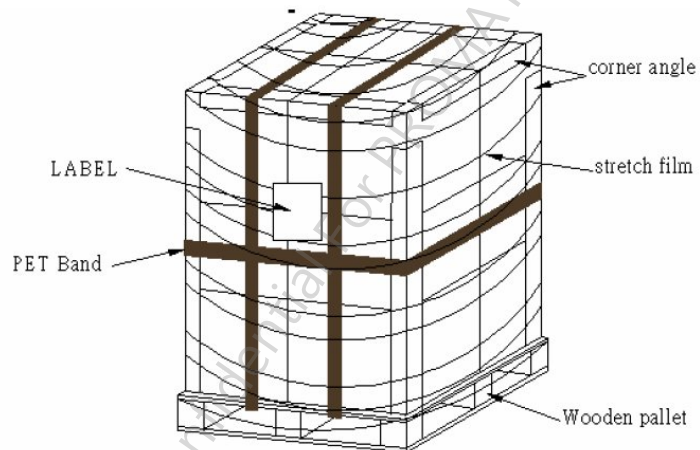
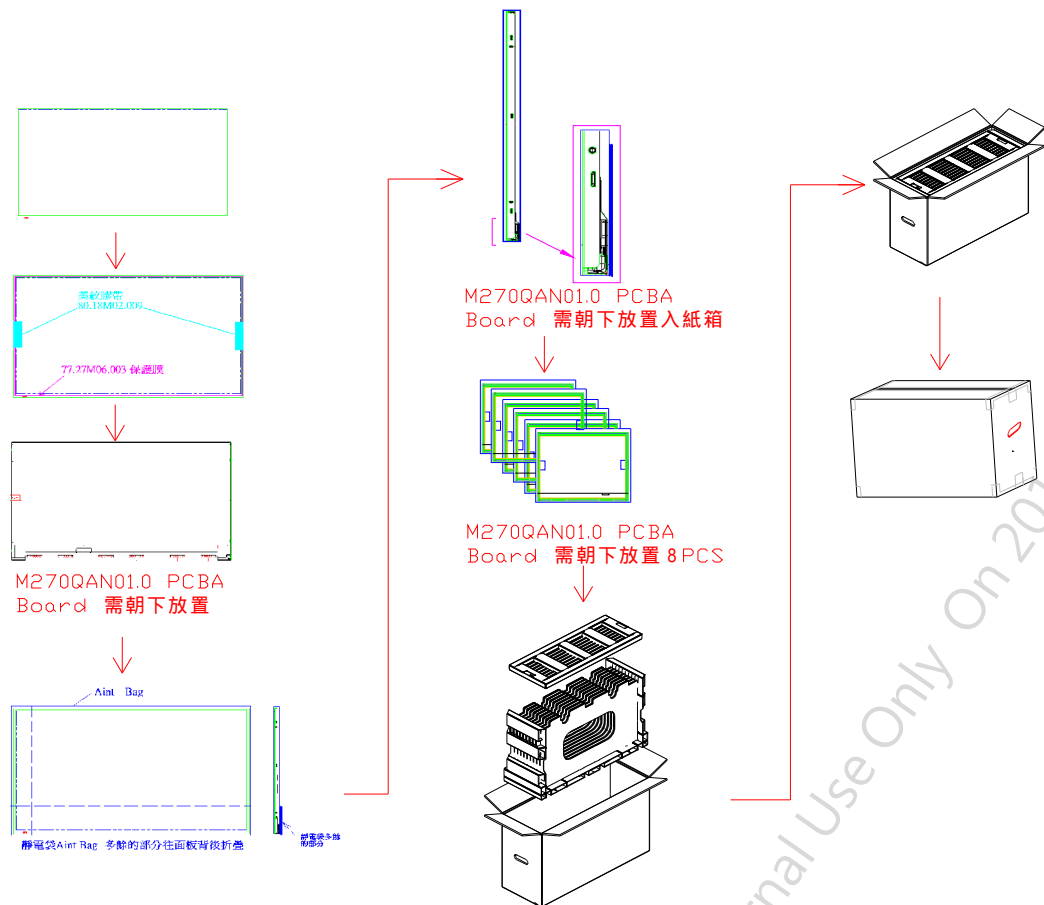

Ver 0.1

8.2 Pallet and shipment information

Item	Specification			Remark
	Q'ty	Dimension	Weight (kg)	
Panel	1	613.6(H)mm × 356.85(V)mm × 14.5(D)mm	2.82	
Cushion	1	-	3.408	
Box	1	720(L)mm x 264(W)mm x 460(H)mm	1.423	without Panel & cushion
Packing Box	8 pcs/Box	720(L)mm x 264(W)mm x 460(H)mm	27.4	with panel & cushion
Pallet	1	1070(L)mm x 740(W)mm x 132(H)mm	14.80	
Pallet after Packing	8 boxes/pallet	1070(L)mm x 740(W)mm x 1086(H)mm	234	

AUO Confidential For PROMATE Internal Use Only On 2016/11/03